

# Truss+ 2010

## Modify Truss System Grid

Chapter One

# Modify Truss System Grid

- Select a truss system grid.
- Choose *Modify Truss System Grid* directly from “Truss+” menu.

The image shows a screenshot of the Revit software interface. The 'Truss+' menu is open, and the 'Modify Truss System Grid' option is highlighted with a red box. A red arrow points from this menu item to the '3D Truss System Grid: Configuration' dialog box. The dialog box displays a 3D model of a truss system and various configuration parameters.

**3D Truss System Grid: Configuration**

Type: Step Down - HE-HRJT-SB108-TCH1.5x3.5

Roof width: 631.874 | Truss thickness: 1.500 | Left roof line: 371.255

Pitch: 25.000 | Top chord depth: 3.500 | Right roof line: 1061.879

Overhang: 24.000 | Setback: 108.000 | Position of „L” return roof ridges:

Truss spacing: 24.000 | First girder ply: 1 |  Form left ridge: 0.000

Second girder ply: 1 |  Form right ridge: 0.000

Truss heel height: 0.000 | Update from roof

Jack configuration...  
 Jack trusses

Setback autosearch left  
 Setback autosearch right  
Actual setback: 0.000  
 Valley trusses will not be used  
Valley pitch: 25.000  
 Valley placement - Top down  
 Valley half spacing  
 Cut bottom chord of Valley  
Sheeting thickness: 0.000

OK Cancel

# Modify Truss System Grid

- If there is a lock symbol near the value of parameter, it means that the truss system grid is attached to the roof (after updating grid from the roof, parameters will be updated automatically, depending on roof geometry).

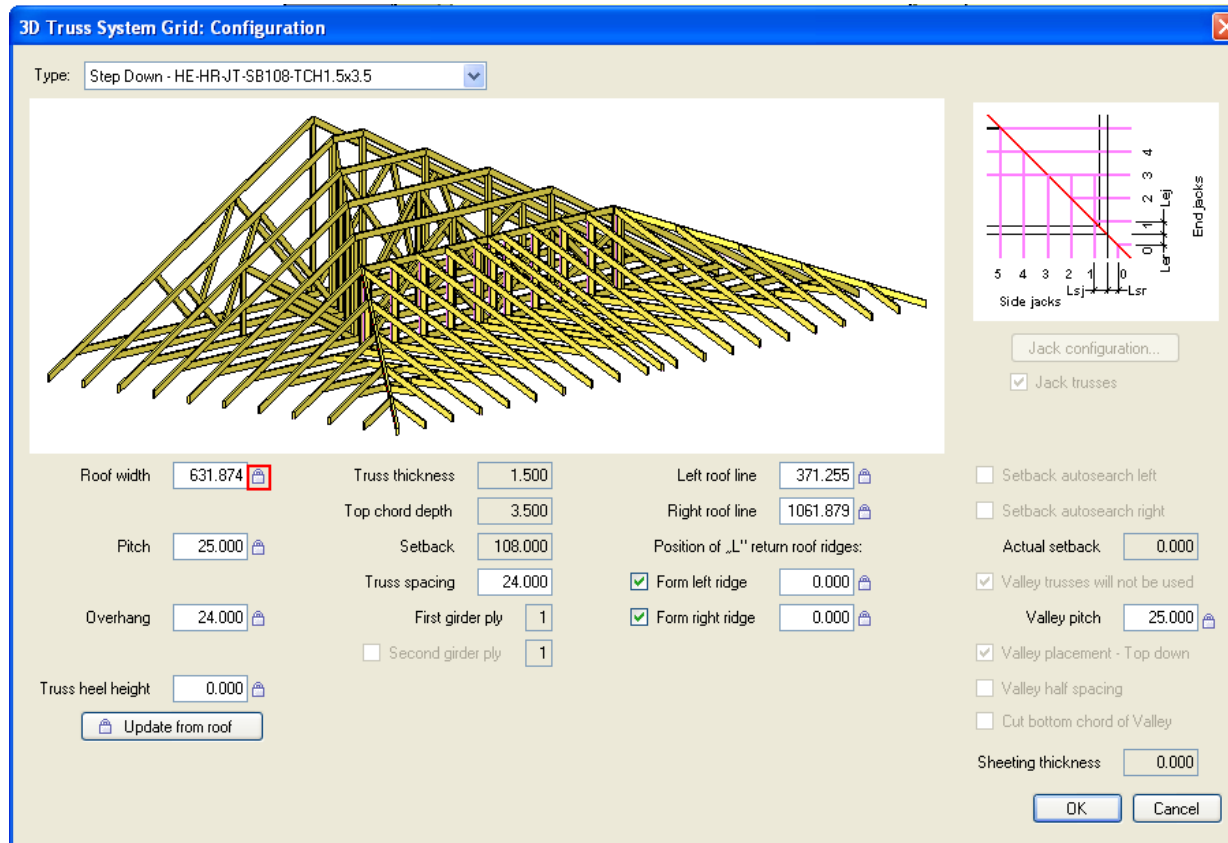

# Modify Truss System Grid

- *Roof width, Left roof line and Right roof line*
- After choosing the command *Update from roof*, parameters with the lock symbol will be updated automatically, depending on the roof geometry.

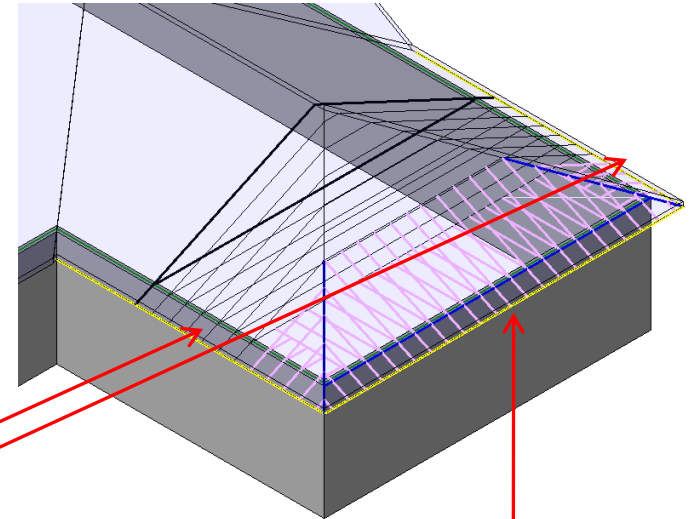
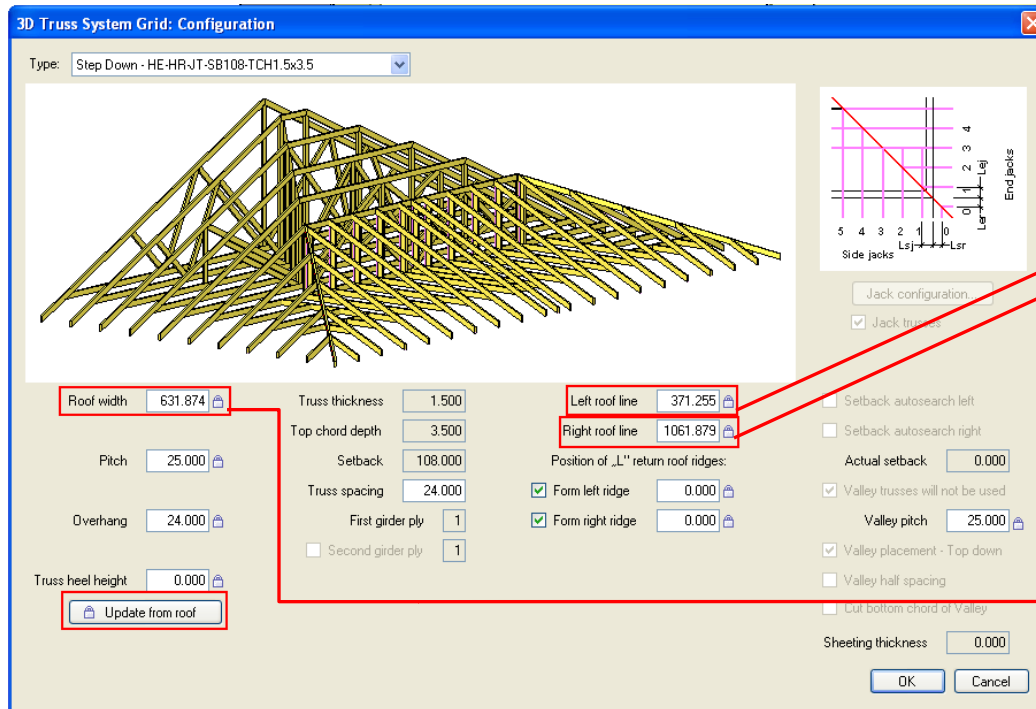

# Modify Truss System Grid

- *Pitch* (slope angle) and *Overhang*
- Roof base offset from level must be equal to *heel height* minus *top chord depth/cos(pitch)* for raised heel or energy trusses.

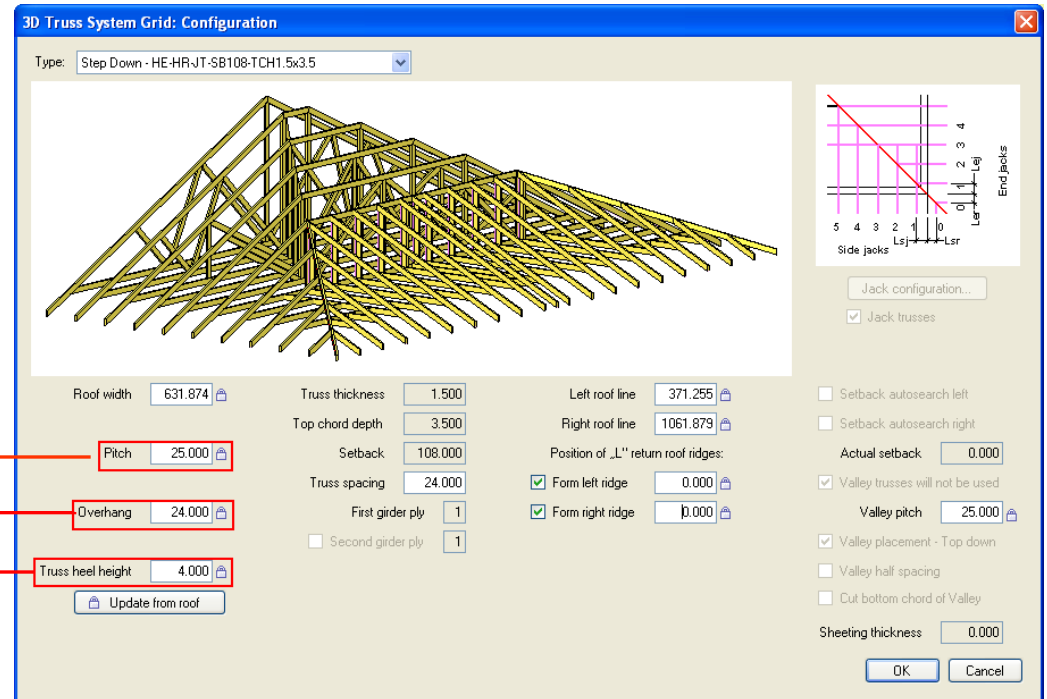
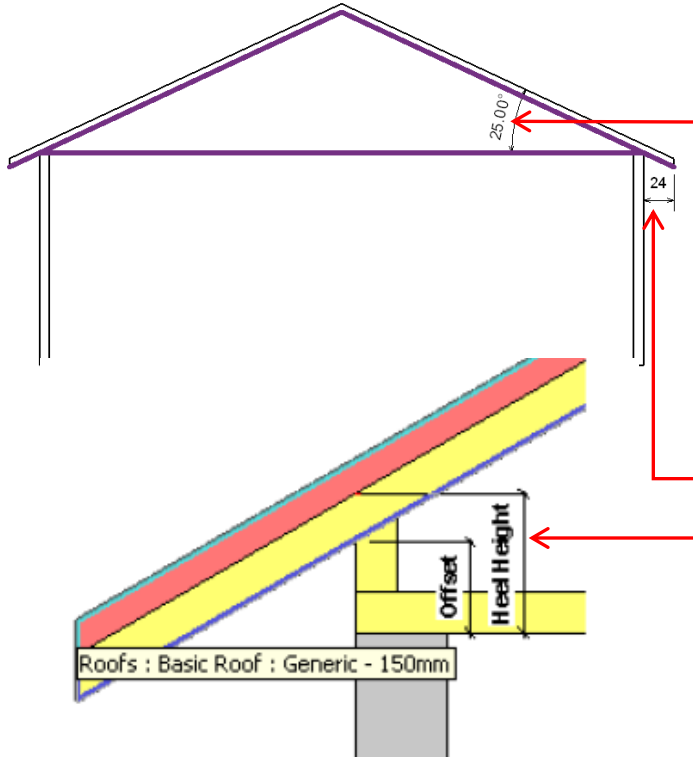

# Modify Truss System Grid

- *First girder ply* parameter describes how many girders will be placed in the first girder place.

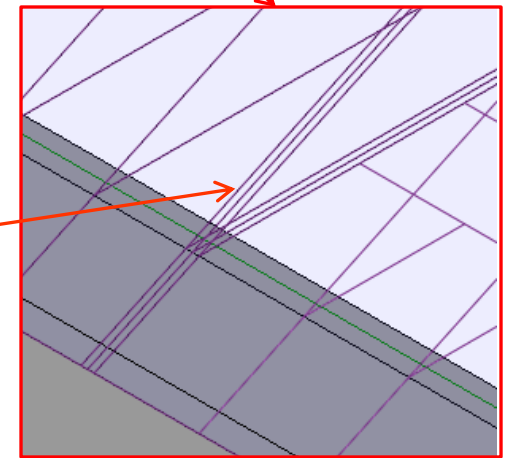
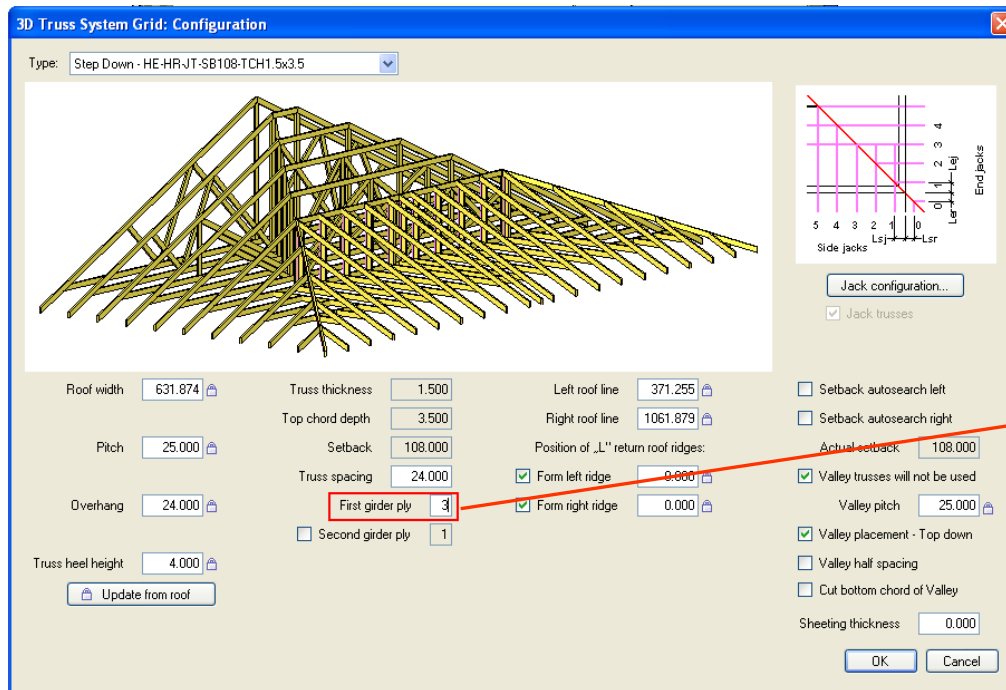
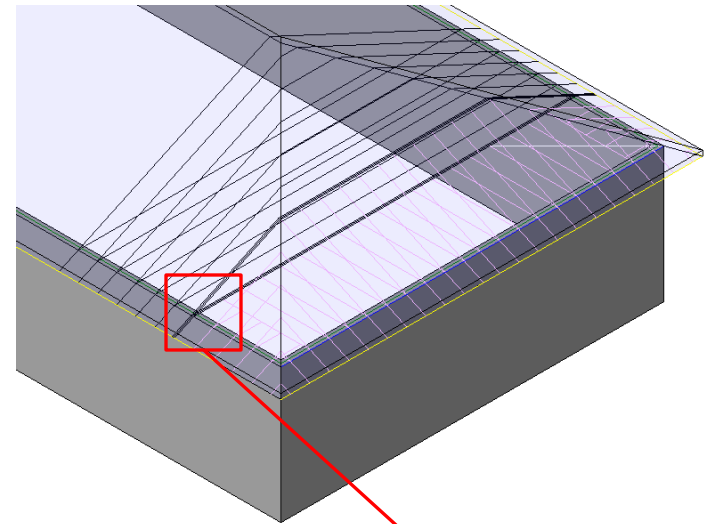

# Modify Truss System Grid

- *Second girder ply* parameter describes how many girders will be placed in the last girder place.

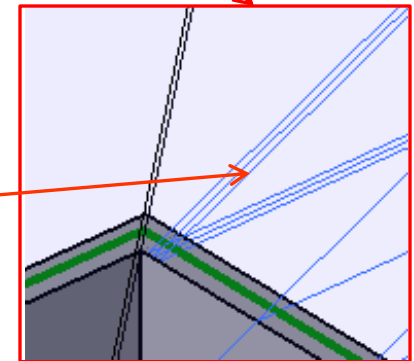
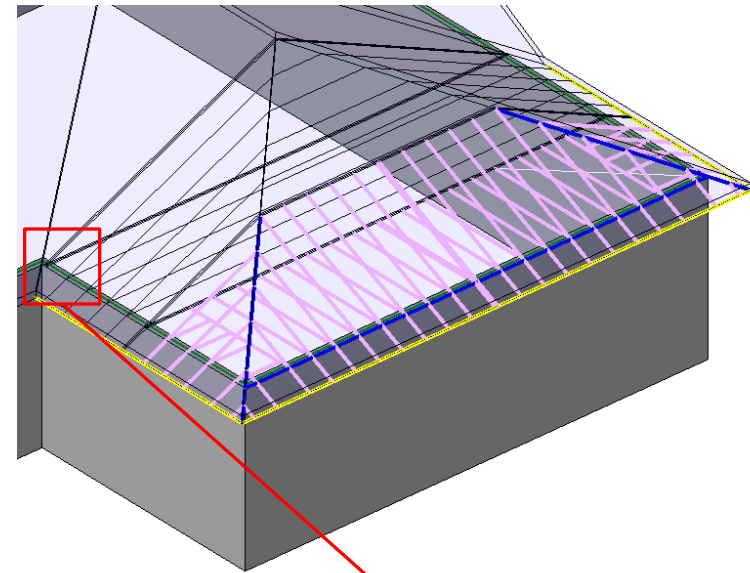
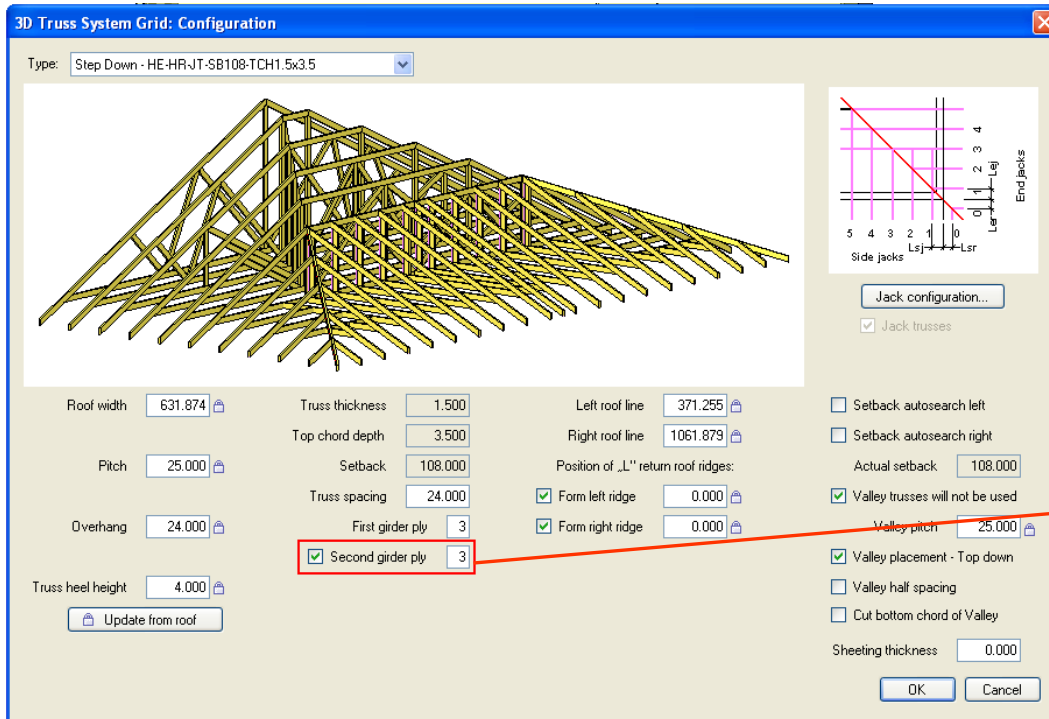

# Modify Truss System Grid

- Position of “L” return roof ridges
- Truss spacing
- Setback – the distance from the core surface to the first girder surface.

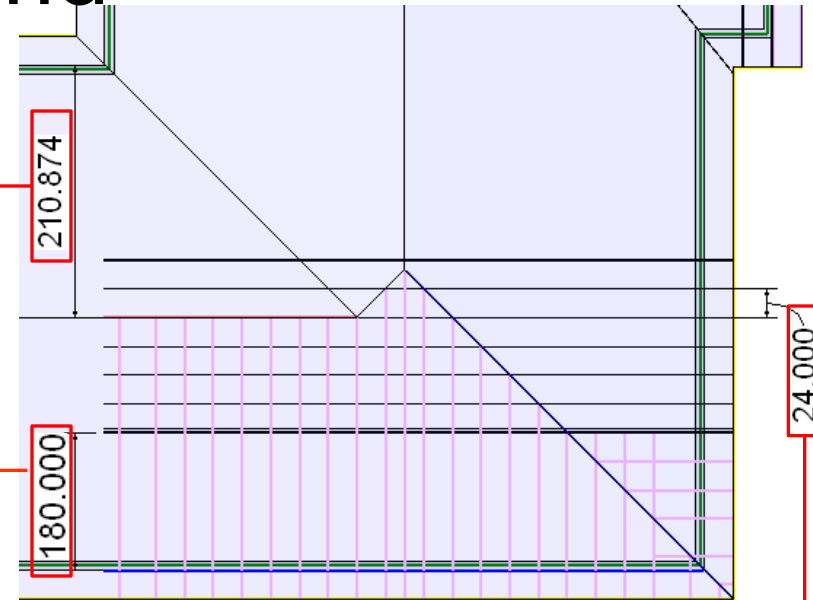

24.000

180.000

210.874

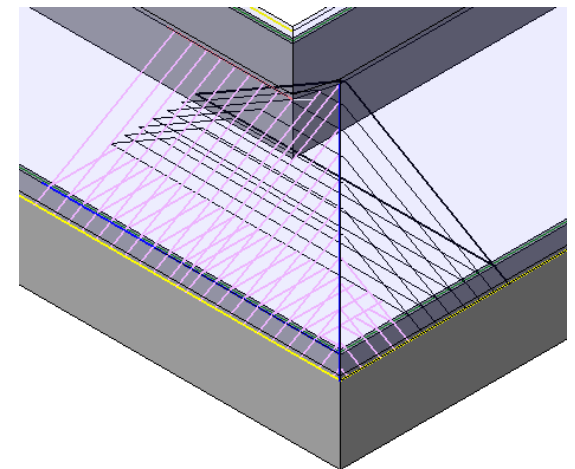
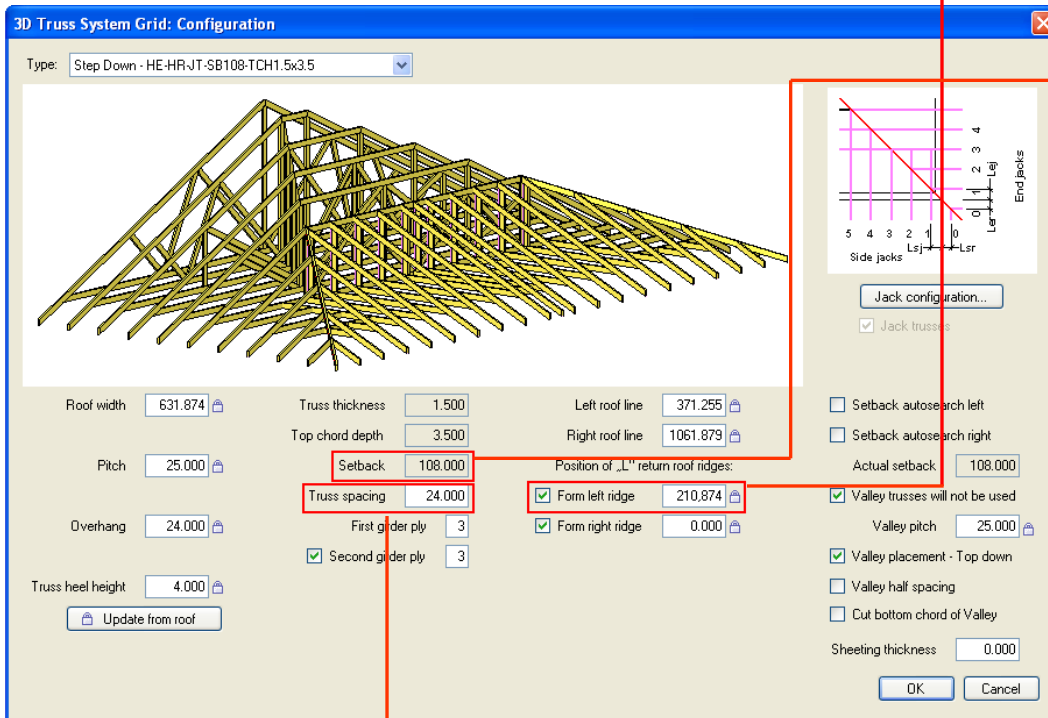

# Increase your productivity !



AGA CAD Ltd.  
Zalgirio 112A, LT-09300 Vilnius,  
Lithuania  
Tel. +370 5 2398111  
Fax +370 5 2398113  
Email [info@aga-cad.lt](mailto:info@aga-cad.lt)  
[info@tools4revit.com](mailto:info@tools4revit.com)  
[www.tools4revit.com](http://www.tools4revit.com)